

# MAINSTREAM ENGINEERING CORP.

## QWIKPAD® FOR CONDENSERS

### EQUIPMENT TIE-DOWN SYSTEM FOR HIGH-VELOCITY HURRICANE-ZONE (HVHZ)

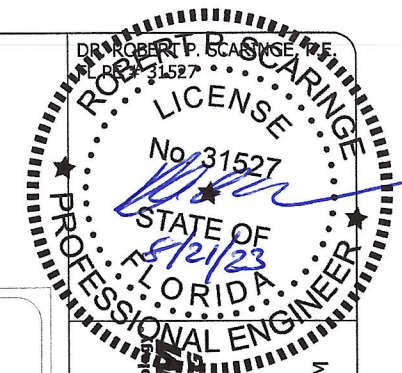

**MAINSTREAM ENGINEERING**  
Solutions Through Advanced Technology

200 YELLOW PLACE  
ROCKLEDGE, FL 32955  
PH: (321) 631-3550  
WWW.MAINSTREAM-ENGR.COM

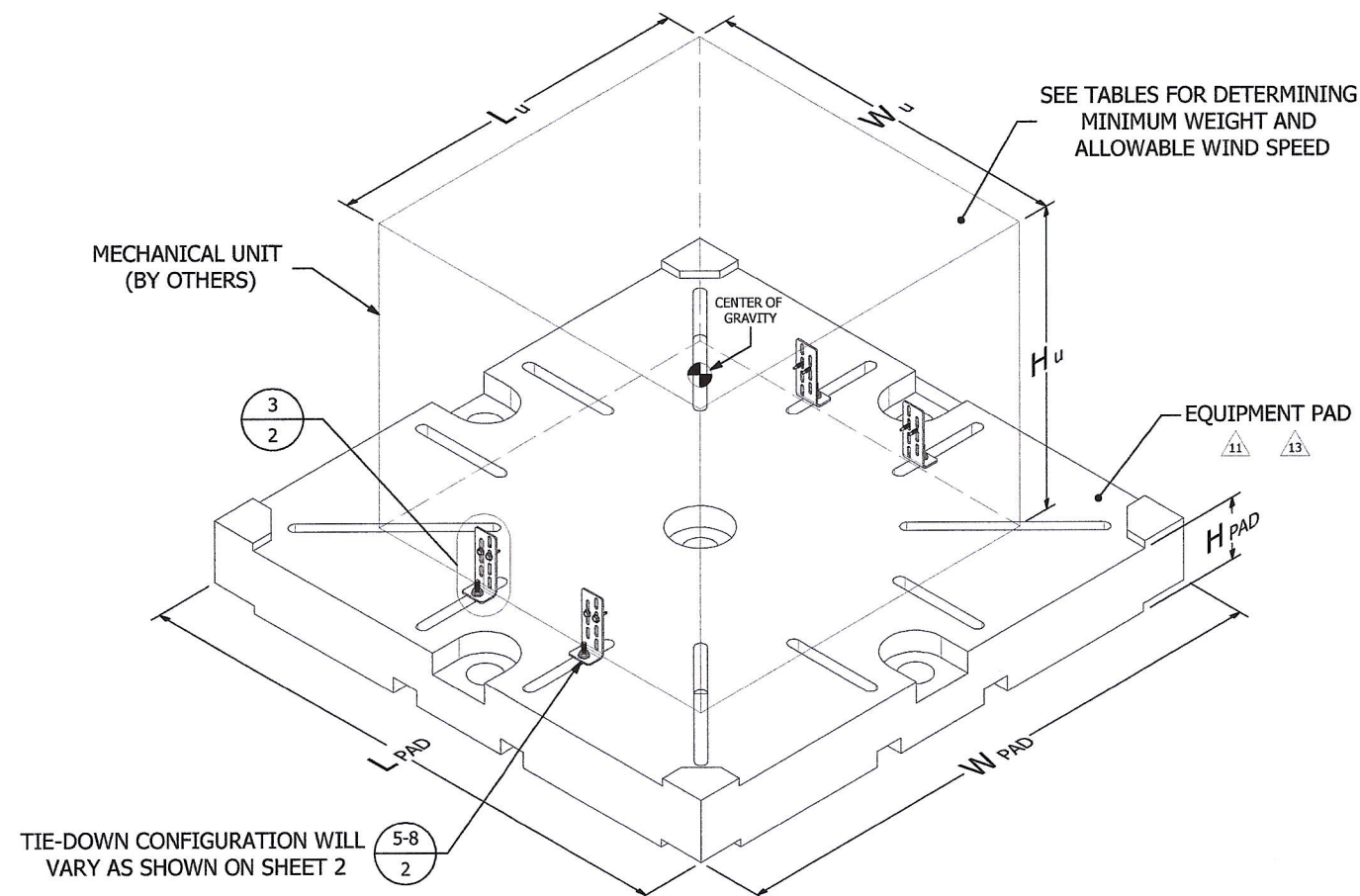

**1** EQUIPMENT TIE-DOWN SYSTEM  
1:10 SCALE ISOMETRIC

#### EQUIPMENT PAD SCHEDULE:

| MODEL  | INSTALLED WEIGHT<br>LB | EQUIPMENT PAD          |                        |                        | ALLOWABLE WIND SPEED<br>MPH | ALLOWABLE PRESSURE<br>PSF | MAX. EQUIPMENT SIZE  |                      |                      | MIN. WEIGHT OF EQUIPMENT |             |
|--------|------------------------|------------------------|------------------------|------------------------|-----------------------------|---------------------------|----------------------|----------------------|----------------------|--------------------------|-------------|
|        |                        | L <sub>PAD</sub><br>IN | W <sub>PAD</sub><br>IN | H <sub>PAD</sub><br>IN |                             |                           | L <sub>u</sub><br>IN | W <sub>u</sub><br>IN | H <sub>u</sub><br>IN | NO ANCHORS               | ANCHORED    |
| QT8036 | 162                    | 36                     | 36                     | 4                      | UP TO 180                   | UP TO 66.3                | 32                   | 32                   | 46                   | SEE TABLE 1              | SEE TABLE 2 |
| QT8040 | 200                    | 40                     | 40                     | 4                      | UP TO 180                   | UP TO 66.3                | 36                   | 36                   | 48                   | SEE TABLE 3              | SEE TABLE 4 |
| -      | -                      | -                      | -                      | -                      | -                           | -                         | -                    | -                    | -                    | -                        | -           |
| -      | -                      | -                      | -                      | -                      | -                           | -                         | -                    | -                    | -                    | -                        | -           |
| -      | -                      | -                      | -                      | -                      | -                           | -                         | -                    | -                    | -                    | -                        | -           |

#### DESIGN NOTES:

1. THIS PRODUCT HAS BEEN DESIGNED IN ACCORDANCE WITH ASCE 7-22 AND THE FLORIDA BUILDING CODE - EIGHTH EDITION (2023) FOR USE WITHIN AND OUTSIDE THE HIGH-VELOCITY HURRICANE ZONE (HVHZ).
  2. DESIGN CONSIDERS ASCE 7-22 SECTION 29.4 DESIGN WIND LOADS: OTHER STRUCTURES. ALL OTHER DESIGN VARIABLES AND LOADING FACTORS ARE IN ACCORDANCE WITH ASCE 7-22 CHAPTERS 26 & 29 FOR EXPOSURE CATEGORY C.
  3. TIE-DOWN CONFIGURATION CONSIDERS A MAXIMUM UNIT HEIGHT OF 48 IN.
  4. PRODUCTS DETAILED HEREIN ARE INCLUDED WITH QWIKPAD® FOR CONDENSERS (SERIES QT80XX) HIGH-VELOCITY HURRICANE ZONE EQUIPMENT MOUNTING PADS. APPROPRIATE PAD SIZE AND ANCHORING ASSUMED TO BE DETERMINED BY CONTRACTOR/INSTALLER BASED ON INSTALLATION SITE.
  5. THIS INSTALLATION SPECIFICATION IS FOR INSTALLATION OF THE EQUIPMENT ATOP ANY 4" QWIKPAD® FOR CONDENSERS (SERIES QT80XX), WITH THE PAD LEVELED AND LOCATED AT GRADE LEVEL OR AT 1" EMBEDMENT ON COMPACTED GROUND OR ATOP EXISTING CONCRETE SLAB.
  6. DESIGN IS BASED ON INSPECTED PRODUCTS AND MANUFACTURING DRAWINGS PRODUCED BY MAINSTREAM ENGINEERING CORP. NO SUBSTITUTIONS WITHOUT WRITTEN APPROVAL BY THIS ENGINEER SHALL BE PERMITTED.
7. 304 STAINLESS STEEL TIE-DOWN BRACKETS AND BOLT RETAINERS SHALL BE ASTM A240 STAINLESS STEEL WITH YIELD STRENGTH=30 KSI OR BETTER.
8. SELF-DRILLING SCREWS SHALL BE AISI 410 STAINLESS STEEL IN ACCORDANCE WITH ASME B18.6.3.
9. CARRIAGE BOLTS SHALL BE 18-8 STAINLESS STEEL PER ASTM F593 IN ACCORDANCE WITH ANSI B18.5 WITH UNC CLASS 2A THREADS (PER ASME B1.1).
10. SERRATED FLANGE HEX NUT MATERIAL SHALL BE 18-8 STAINLESS STEEL WITH UNC CLASS 2B THREADS (PER ASME B1.1).
11. EQUIPMENT PAD SHALL BE LOW-DENSITY POLYETHYLENE (LDPE) WITH YIELD STRENGTH = 1.675 KSI OR BETTER PER ASTM D638 AND NOMINAL WALL THICKNESS = .220 (.1875 MIN.).
12. GROUND OR CONCRETE ANCHORS SHALL BE USED IN ACCORDANCE WITH PROVIDED DESIGN TABLES 1-4. ALL ANCHORS MUST HAVE MIN. PULL-OUT RATING OF 205 LBS EACH.
13. EQUIPMENT PAD SHALL BE FILLED WITH WATER AT INSTALLATION SITE TO ACHIEVE WEIGHTS GIVEN IN EQUIPMENT PAD SCHEDULE TABLE.

#### GENERAL NOTES:

1. NO 33-1/3% INCREASE IN ALLOWABLE STRESS HAS BEEN USED IN THE DESIGN OF THIS SYSTEM.
2. MAXIMUM AND MINIMUM DIMENSIONS AND MINIMUM WEIGHT OF UNIT SHALL CONFORM TO SPECIFICATIONS STATED IN RESPECTIVE QWIKPAD® FOR CONDENSERS (SERIES QT80XX) ENGINEERING DOCUMENTS.
3. CENTER OF GRAVITY ASSUMED TO ACT AT GEOMETRIC CENTER OF UNIT.
4. TIE-DOWN ASSEMBLY CONFIGURATION TO BE INSTALLED PER ONE OF THE DEPICTED CONFIGURATION VIEWS.
5. THE CONTRACTOR SHALL BE RESPONSIBLE TO INSULATE ALL MEMBERS FROM DISSIMILAR METALS TO PREVENT ELECTROLYSIS.
6. ELECTRICAL GROUND, WHEN REQUIRED, SHALL BE DESIGNED AND INSTALLED BY OTHERS.
7. THE SYSTEM DETAILED HEREIN IS GENERIC AND DOES NOT PROVIDE INFORMATION FOR A SPECIFIC SITE. FOR SITE CONDITIONS DIFFERENT FROM THE CONDITIONS DETAILED HEREIN, A LICENSED ENGINEER SHALL PREPARE SITE SPECIFIC DOCUMENTS IN CONJUNCTION WITH THIS DOCUMENT.
8. FOR AN EXPLANATION OF RISK AND EXPOSURE CATEGORIES THAT ACCOMPANY THE VULT WIND SPEEDS USED IN THIS APPROVAL, SEE SECTIONS 1.5.1 AND 26.7.3, RESPECTIVELY, OF ASCE 7-22. VULT WIND SPEEDS FOR RISK CATEGORY II DETERMINED BY FIGURE 26.5-1B OF ASCE 7-22. LINEAR INTERPOLATION PERMITTED BETWEEN CONTOURS.
9. ALL DIMENSIONS SHOWN ARE REFERENCE AND IN INCHES, UNLESS OTHERWISE SPECIFIED.

**QWIKPAD® FOR CONDENSERS**  
EQUIPMENT TIE-DOWN SYSTEM FOR HVHZ

FBC 8TH EDITION (2023) PRODUCT APPROVAL  
**FL# 25896.1**

| REV | REMARKS   | DRWN         | CHKD         | DATE       |
|-----|---|--------------|--------------|------------|
| A   | INITIAL RELEASE                                   | A. CARPENTER | R. SCARINGE  | 04/30/2018 |
| B   | UPDATE FOR FBC 7TH EDITION & ASCE 7-16 COMPLIANCE | B. WOODS     | A. CARPENTER | 12/10/2020 |
| C   | UPDATE FOR FBC 8TH EDITION & ASCE 7-22, 19 TO R   | T. ABBOTT    | A. CARPENTER | 08/17/2023 |

NOTICE: THIS DOCUMENT IS THE PROPERTY OF MAINSTREAM ENGINEERING CORPORATION AND SHALL NOT BE REPRODUCED IN WHOLE OR PART WITHOUT WRITTEN CONSENT OF MAINSTREAM ENGINEERING CORPORATION. ALTERATIONS, ADDITIONS, HIGHLIGHTING, OR OTHER MARKINGS TO THIS DOCUMENT ARE NOT PERMITTED AND INVALIDATE THIS CERTIFICATION.

**QT8000**  
SERIES

DWG NO. 5010248 REV C

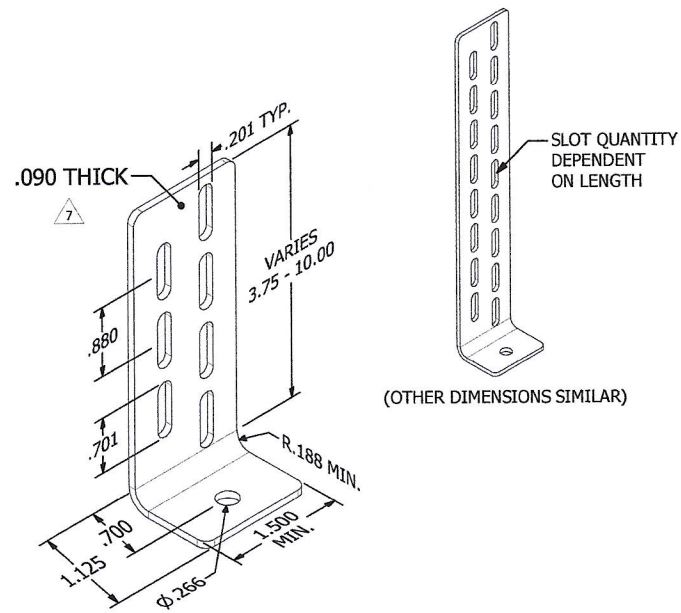

**1** TIE-DOWN BRACKET  
1:2 SCALE ISOMETRIC

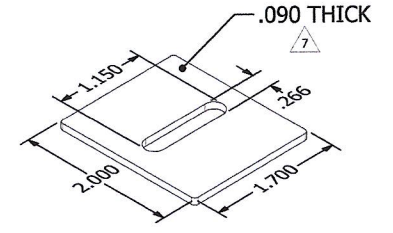

**2** BOLT RETAINER  
1:2 SCALE ISOMETRIC

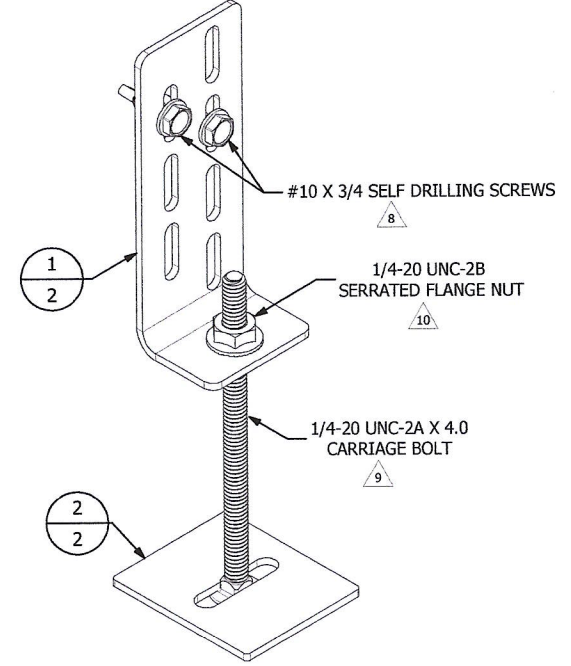

**3** TIE-DOWN ASSEMBLY  
1:2 SCALE ISOMETRIC

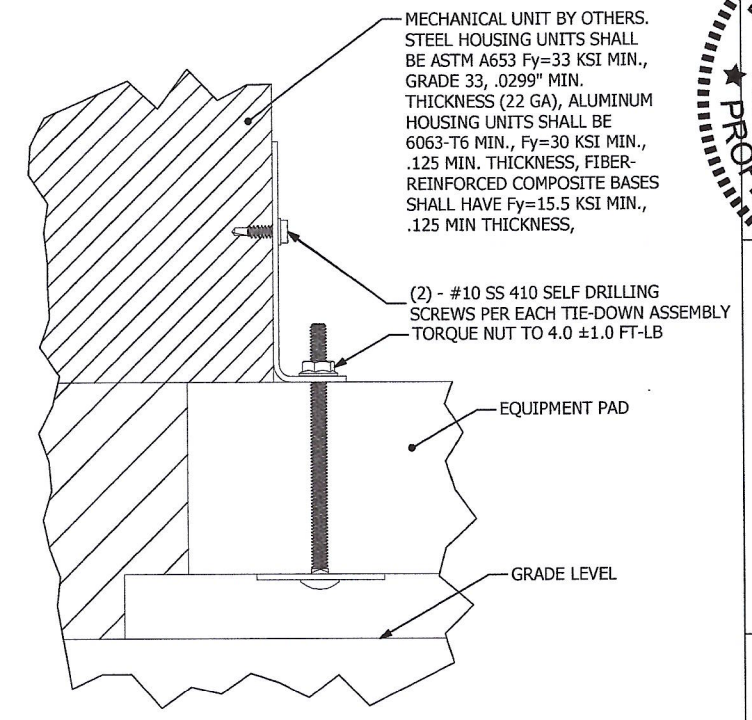

**4** UNIT TIE-DOWN DETAIL  
1:3 SCALE DETAIL

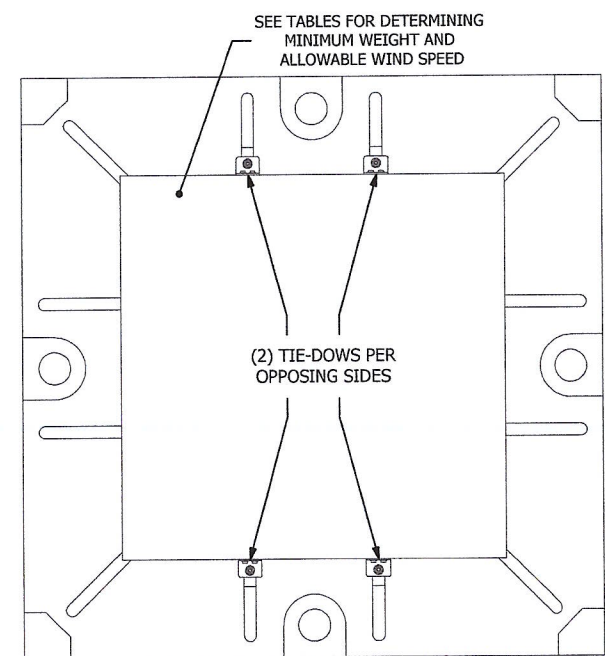

1. TIE-DOWN CONFIGURATION APPLICABLE TO SQUARE, RECTANGULAR OR ROUND† UNITS.
2. TIE-DOWN CONFIGURATION APPLICABLE FOR USE WITH EQUIPMENT PAD MODELS QT8036 AND QT8040.

**5** TIE-DOWN CONFIGURATION  
1:16 SCALE TOP VIEW

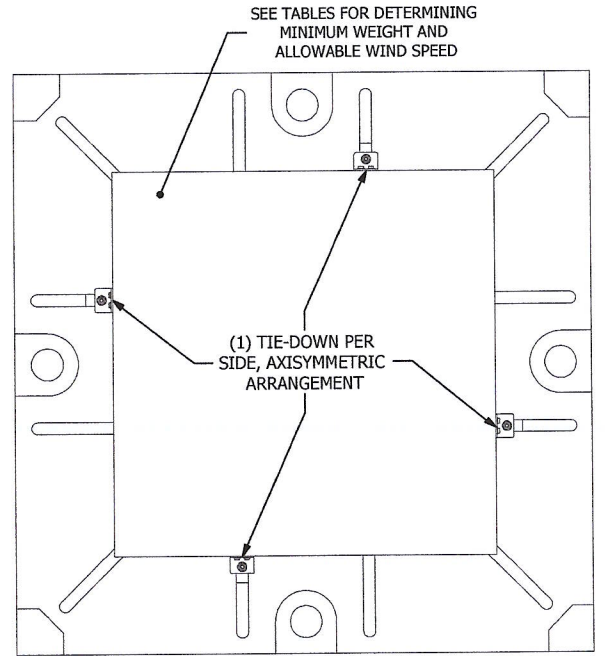

1. ALTERNATE TIE-DOWN CONFIGURATION APPLICABLE TO SQUARE, RECTANGULAR OR ROUND† UNITS.
2. TIE-DOWN CONFIGURATION APPLICABLE FOR USE WITH EQUIPMENT PAD MODELS QT8036 AND QT8040.

**6** TIE-DOWN CONFIG. - ALT.  
1:16 SCALE TOP VIEW

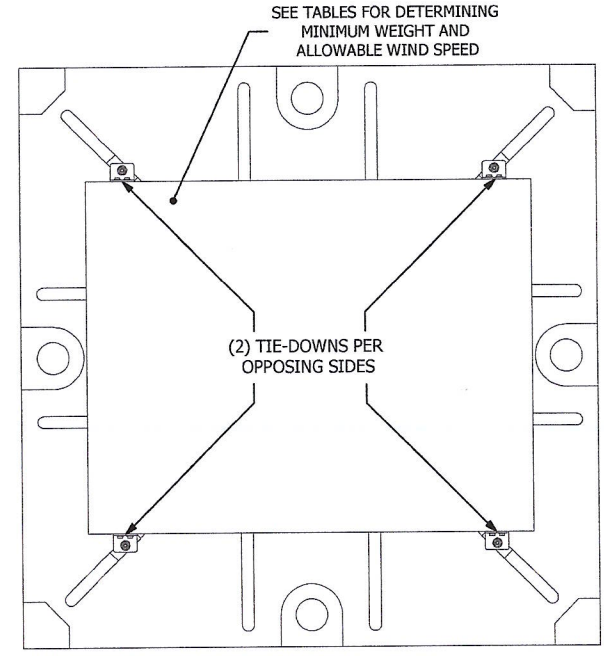

1. ALTERNATE TIE-DOWN CONFIGURATION USING DIAGONAL SLOTS APPLICABLE FOR RECTANGULAR UNITS.
2. TIE-DOWN CONFIGURATION APPLICABLE FOR USE WITH EQUIPMENT PAD MODELS QT8036 AND QT8040.

**7** TIE-DOWN CONFIG. - ALT. RECT  
1:16 SCALE TOP VIEW

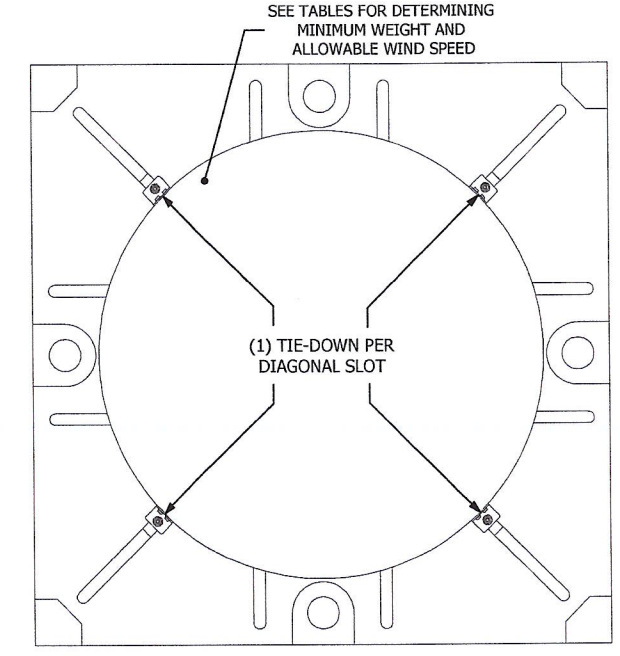

1. ALTERNATE TIE-DOWN CONFIGURATION USING DIAGONAL SLOTS APPLICABLE FOR ROUND† UNITS OR SQUARE UNITS WITH ROUNDED CORNERS.
2. TIE-DOWN CONFIGURATION APPLICABLE FOR USE WITH EQUIPMENT PAD MODELS QT8036 AND QT8040.

**8** TIE-DOWN CONFIG. - ALT. RND  
1:16 SCALE TOP VIEW

† ROUND UNITS MUST ASSUME LENGTH (L<sub>u</sub>) AND WIDTH (W<sub>u</sub>) USED IN TABLES TO BE EQUAL TO DIAMETER OF UNIT.

ROBERT P. SCARINGE  
# 81527  
LICENSE  
No. 81527  
STATE OF  
FLORIDA  
PROFESSIONAL ENGINEER

Solutions Through Advanced Technology  
**MAINSTREAM ENGINEERING**

200 YELLOW PLACE  
ROCKLEDGE, FL 32955  
PH: (321) 631-3550  
WWW.MAINSTREAM-ENGR.COM

**QWIKPAD® FOR CONDENSERS**  
EQUIPMENT TIE-DOWN SYSTEM FOR HVHZ

FBC 8TH EDITION (2023) PRODUCT APPROVAL  
**FL # 25896.1**

| REV | REMARKS   | DRWN         | CHKD         | DATE       |
|-----|---|--------------|--------------|------------|
| A   | INITIAL RELEASE                                   | A. CARPENTER | R. SCARINGE  | 04/30/2018 |
| B   | UPDATE FOR FBC 7TH EDITION & ASCE 7-16 COMPLIANCE | B. WOODS     | A. CARPENTER | 12/10/2020 |
| C   | UPDATE FOR FBC 8TH EDITION & ASCE 7-22, TM TO R   | T. ABBOTT    | A. CARPENTER | 08/17/2023 |

NOTICE: THIS DOCUMENT IS THE PROPERTY OF MAINSTREAM ENGINEERING CORPORATION AND SHALL NOT BE REPRODUCED IN WHOLE OR PART WITHOUT WRITTEN CONSENT OF MAINSTREAM ENGINEERING CORPORATION. ALTERATIONS, ADDITIONS, HIGHLIGHTING, OR OTHER MARKINGS TO THIS DOCUMENT ARE NOT PERMITTED AND INVALIDATE THIS CERTIFICATION.

QT8036 EQUIPMENT PAD

TABLE 1. MINIMUM WEIGHT OF EQUIPMENT REQUIRED FOR VULT = 130 MPH, 150 MPH, AND 180 MPH (EXPOSURE 'C') USING QT8036 EQUIPMENT PAD (FOR USE WITH RISK CATEGORY II STRUCTURE IN THE HIGH-VELOCITY HURRICANE ZONE)

Table with columns for Equipment Dimensions (L\_u, W\_u, H\_u), VULT = 130 MPH Allowable Wind Speed (35.0 PSF), VULT = 150 MPH Allowable Wind Speed (46.0 PSF), and VULT = 180 MPH Allowable Wind Speed (66.3 PSF). Each section contains sub-columns for Min. Weight, .6 X Unit + Pad, Dead Load Moment, Fwind, Tot, Fwind, Unit, .6 X Wind Moment, and Design Check.

PROCEDURE FOR USE OF TABLE 1 FOR EQUIPMENT PAD MODEL QT8036:

- 1. DETERMINE SIZE AND WEIGHT OF EQUIPMENT TO BE INSTALLED.
2. FIND APPROPRIATE EQUIPMENT SIZE IN TABLE. (IF UNIT SIZE IS BETWEEN LISTED DIMENSIONS, USE NEXT LARGER SIZE IN TABLE.)
3. FOR A GIVEN WIND SPEED, DETERMINE IF WEIGHT OF EQUIPMENT TO BE INSTALLED MEETS MIN. WEIGHT OF EQUIPMENT REQUIREMENT. IF SO, DESIGN IS OK FOR GIVEN WIND SPEED.
NOTE: IF EQUIPMENT DOES NOT MEET MIN. WEIGHT OF EQUIPMENT REQUIREMENT, OR IF NOTED OTHERWISE, ANCHORS ARE REQUIRED - SEE TABLE 2.

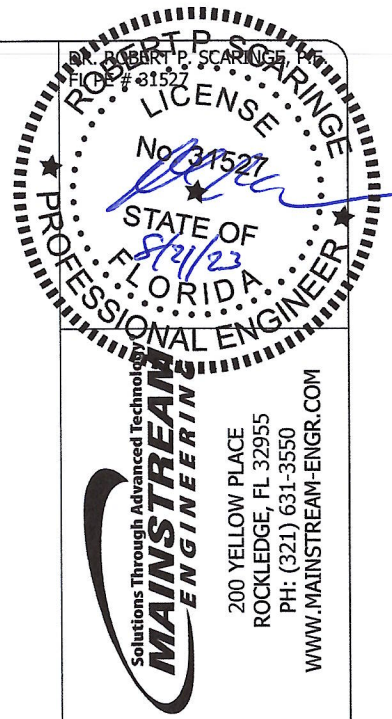

Mainstream Engineering logo and address: 200 YELLOW PLACE, ROCKLEDGE, FL 32955, PH: (321) 631-3550, WWW.MAINSTREAM-ENGR.COM

QWIKPAD FOR CONDENSERS EQUIPMENT TIE-DOWN SYSTEM FOR HVHZ, QWIKPAD FOR CONDENSERS EQUIPMENT TIE-DOWN SYSTEM FOR HVHZ, FL# 25896.1

Table with columns: REV, REMARKS, DRWN, CHKD, DATE. Includes revision history and initials for R. Scaringe, A. Carpenter, B. Woods, T. Abbott.

NOTICE: THIS DOCUMENT IS THE PROPERTY OF MAINSTREAM ENGINEERING CORPORATION AND SHALL NOT BE REPRODUCED IN WHOLE OR PART WITHOUT WRITTEN CONSENT OF MAINSTREAM ENGINEERING CORPORATION.

**QT8036 EQUIPMENT PAD - ANCHORED**

**TABLE 2. MINIMUM WEIGHT OF EQUIPMENT REQUIRED FOR VULT = 130 MPH, 150 MPH, AND 180 MPH (EXPOSURE 'C') USING QT8036 EQUIPMENT PAD AND ANCHORS (FOR USE WITH RISK CATEGORY II STRUCTURE IN THE HIGH-VELOCITY HURRICANE ZONE)**

| EQUIPMENT DIMENSIONS |                |                | VULT = 130 MPH ALLOWABLE WIND SPEED<br>(35.0 PSF ALLOWABLE WIND PRESSURE)<br>2 ANCHORS REQUIRED |                   |                    |                       |                        |                    |                | VULT = 150 MPH ALLOWABLE WIND SPEED<br>(46.0 PSF ALLOWABLE WIND PRESSURE)<br>2 ANCHORS REQUIRED |                   |                    |                       |                        |                    |                | VULT = 180 MPH ALLOWABLE WIND SPEED<br>(66.3 PSF ALLOWABLE WIND PRESSURE)<br>2 ANCHORS REQUIRED |                   |                    |                       |                        |                    |                | VULT = 180 MPH ALLOWABLE WIND SPEED<br>(66.3 PSF ALLOWABLE WIND PRESSURE)<br>4 ANCHORS REQUIRED |                   |                    |                       |                        |                    |                |
|----------------------|----------------|----------------|---|-------------------|--------------------|-----------------------|------------------------|--------------------|----------------|---|-------------------|--------------------|-----------------------|------------------------|--------------------|----------------|---|-------------------|--------------------|-----------------------|------------------------|--------------------|----------------|---|-------------------|--------------------|-----------------------|------------------------|--------------------|----------------|
| L <sub>u</sub>       | W <sub>u</sub> | H <sub>u</sub> | MIN. WEIGHT OF EQUIPMENT  | .6 X (UNIT + PAD) | DEAD LOAD + ANCHOR | F <sub>WIND,TOT</sub> | F <sub>WIND,UNIT</sub> | .6 X (WIND MOMENT) | DESIGN CHECK   | MIN. WEIGHT OF EQUIPMENT  | .6 X (UNIT + PAD) | DEAD LOAD + ANCHOR | F <sub>WIND,TOT</sub> | F <sub>WIND,UNIT</sub> | .6 X (WIND MOMENT) | DESIGN CHECK   | MIN. WEIGHT OF EQUIPMENT  | .6 X (UNIT + PAD) | DEAD LOAD + ANCHOR | F <sub>WIND,TOT</sub> | F <sub>WIND,UNIT</sub> | .6 X (WIND MOMENT) | DESIGN CHECK   | MIN. WEIGHT OF EQUIPMENT  | .6 X (UNIT + PAD) | DEAD LOAD + ANCHOR | F <sub>WIND,TOT</sub> | F <sub>WIND,UNIT</sub> | .6 X (WIND MOMENT) | DESIGN CHECK   |
| L <sub>u</sub>       | W <sub>u</sub> | H <sub>u</sub> | LB  | LB                | FT-LB              | LB                    | LB                     | FT-LB              | -              | LB  | LB                | FT-LB              | LB                    | LB                     | FT-LB              | -              | LB  | LB                | FT-LB              | LB                    | LB                     | FT-LB              | -              | LB  | LB                | FT-LB              | LB                    | LB                     | FT-LB              | -              |
| 22                   | 22             | 26             | 0   | 97.2              | 514.8              | 171.7                 | 137.2                  | 120.1              | OK FOR 130 MPH | 0   | 97.2              | 514.8              | 228.7                 | 182.7                  | 159.9              | OK FOR 150 MPH | 0   | 97.2              | 514.8              | 329.3                 | 263.0                  | 230.2              | OK FOR 180 MPH | 0   | 97.2              | 883.8              | 329.3                 | 263.0                  | 230.2              | OK FOR 180 MPH |
| 32                   | 32             | 46             | 0   | 97.2              | 514.8              | 387.6                 | 353.1                  | 480.1              | OK FOR 130 MPH | 139   | 180.6             | 639.9              | 516.1                 | 470.1                  | 639.2              | OK FOR 150 MPH | 42  | 122.4             | 921.6              | 743.1                 | 676.9                  | 920.4              | OK FOR 180 MPH | 42  | 122.4             | 921.6              | 743.1                 | 676.9                  | 920.4              | OK FOR 180 MPH |

**ANCHOR SCHEDULE:**

| SUBSTRATE                               | DESCRIPTION   | PULL-OUT STRENGTH  |
|---|---|--------------------|
| GROUND/SOIL (LEVELED, COMPACTED)        | A356 AL, SHEAR = 20KSI MIN., UTS = 26KSI MIN., Ø1.75" FLIGHT, 1.125" THREAD PITCH, 22" LONG (19" EMBED TO GROUND)                                   | 205 LB MIN. (EACH) |
| CONCRETE (4" MIN. THICK, 2000 PSI MIN.) | Ø1/4" X 4" ITW TAPCON CONCRETE SCREWS, 1.25" EMBED TO CONCRETE, 4" MIN. SPACING, 2.5" EDGE DISTANCE, MUST USE Ø3" 304 SS FENDER WASHER (13 GA MIN.) | 205 LB MIN. (EACH) |

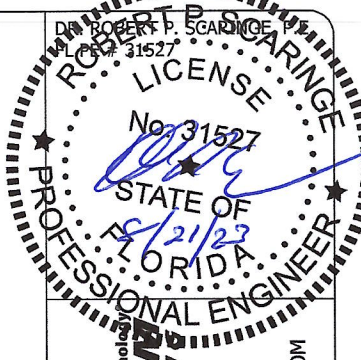

**MAINSTREAM ENGINEERING**  
Solutions Through Advanced Technology  
200 YELLOW PLACE  
ROCKLEDGE, FL 32955  
PH: (321) 631-3550  
WWW.MAINSTREAM-ENGR.COM

**QWIKPAD® FOR CONDENSERS**  
EQUIPMENT TIE-DOWN SYSTEM FOR HVHZ  
FBC 8TH EDITION (2023) PRODUCT APPROVAL  
FL# 25896-1

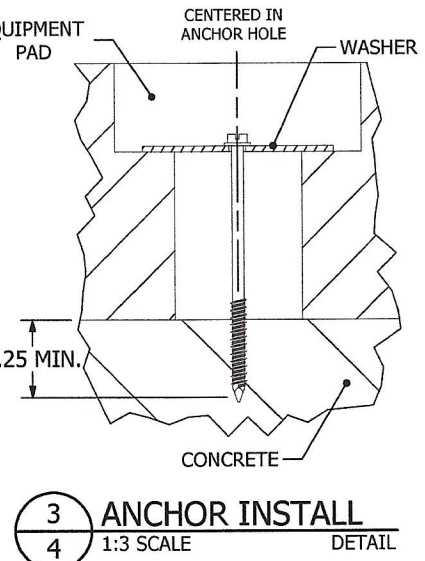

**PROCEDURE FOR USE OF TABLE 2 FOR EQUIPMENT PAD MODEL QT8036 WITH ANCHORS:**

- DETERMINE SIZE AND WEIGHT OF EQUIPMENT TO BE INSTALLED.
  - FIND APPROPRIATE EQUIPMENT SIZE IN TABLE. (IF UNIT SIZE IS BETWEEN LISTED DIMENSIONS, USE NEXT LARGER SIZE IN TABLE.)
  - FOR A GIVEN WIND SPEED AND ANCHOR QUANTITY, DETERMINE IF WEIGHT OF EQUIPMENT TO BE INSTALLED MEETS MIN. WEIGHT OF EQUIPMENT REQUIREMENT. IF SO, DESIGN IS OK FOR GIVEN WIND SPEED WITH THE USE OF GIVEN ANCHOR QUANTITY.
- NOTE: (2) ANCHORS MUST BE INSTALLED ON OPPOSING SIDES OF EQUIPMENT PAD AS SHOWN IN '(2) ANCHOR PLACEMENT QT8036' VIEW.

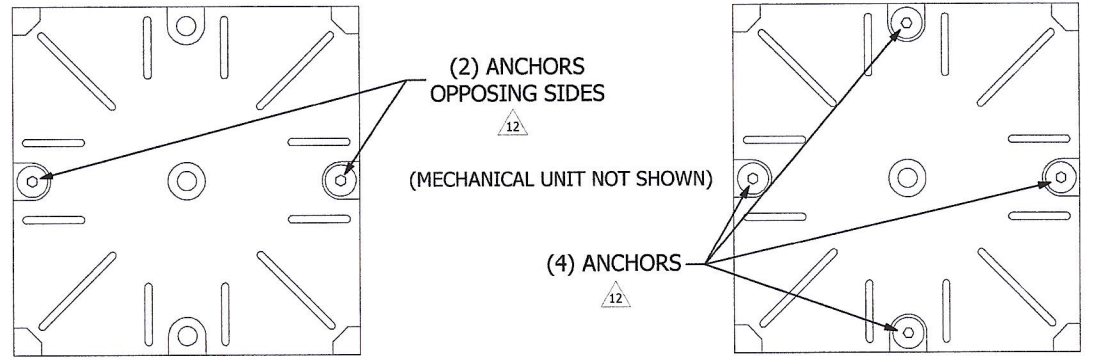

**(1) (2) ANCHOR PLACEMENT QT8036**  
1:20 SCALE TOP VIEW

**(2) (4) ANCHOR PLACEMENT QT8036**  
1:20 SCALE TOP VIEW

| REV | REMARKS   | DRWN         | CHKD         | DATE       |
|-----|---|--------------|--------------|------------|
| A   | INITIAL RELEASE                                   | A. CARPENTER | R. SCARINGE  | 04/30/2018 |
| B   | UPDATE FOR FBC 8TH EDITION & ASCE 7-16 COMPLIANCE | B. WOODS     | A. CARPENTER | 12/10/2020 |
| C   | UPDATE FOR FBC 8TH EDITION & ASCE 7-22, TM TO R.  | T. ABBOTT    | A. CARPENTER | 08/17/2023 |



